



57460 Dewitt Street ■ Elkhart, Indiana 46517-1078
Phone (574) 293-9096 ■ Fax (574) 294-3450
800-628-2957 ■ Web site: www.roofingproductsint.com



ARCHITECTURAL SPECIFICATIONS LOOSE LAID & BALLAST SYSTEM

B1.00	GENERAL
B1.01	APPLICABILITY
B1.02	RELATED WORK
B1.03	QUALITY ASSURANCE AND WARRANTY
B1.04	DESIGN CONSIDERATIONS
B1.05	ROOF DRAWINGS
B1.06	ROOF DECK AND FLASHING SURFACES
B1.07	JOB CONDITIONS
B1.08	STORAGE OF MATERIALS
B1.09	SURFACE PREPARATION
B2.00	MATERIALS
B2.01	MEMBRANE AND FLASHING MATERIAL SPECIFICATIONS
B2.02	COMPONENT MATERIALS
B3.00	WORKMANSHIP AND APPLICATION
B3.01	INSULATION INSTALLATION
B3.02	MEMBRANE INSTALLATION
B3.03	SPLICING
B3.04	NAILERS
B3.05	FLASHING
B3.06	NIGHT SEAL
B3.07	WALKWAY PADS
B3.08	PROTECTION
B3.09	CLEANUP



57460 Dewitt Street ■ Elkhart, Indiana 46517-1078
Phone (574) 293-9096 ■ Fax (574) 294-3450
800-628-2957 ■ Web site: www.roofingproductsint.com



Royal Edge EPDM Roofing Membrane is loose laid over existing insulation or substrate and held down with 3/4 to 2 1/2 inch river washed stone, concrete pavers. An RPI approved FM or UL insulation is fastened as per local wind requirements and/or specifications. Flashing and termination details are shown on the detail sheets. Splices are made with RPI Seam Tape or with RPI Rubber-to-Rubber Splice Adhesive and are protected with a bead of RPI Lap Sealant (Paste Sealant).

B1.00 GENERAL

B1.01 APPLICABILITY

The Loose Laid and Ballast roofing system is appropriate for most commercial and industrial applications. Please consult RPI regarding roofs with the following conditions:

1. Exhaust fans discharging chemical or petroleum products onto the roof.
2. Irregular slopes.
3. Slopes greater than 1" in 12".
4. Roofs classified Zone III by Factory Mutual's Loss Prevention Data Bulletin I-28.
5. Roofs subject to special code requirements.
6. Ponding Water.

B1.02 RELATED WORK

It is RPI's policy not to warrant metal, nailers, tie-ins, or other materials not sold or manufactured by RPI. Because the roofing integrity depends on this related work, please refer to detail drawings for recommended fastening and membrane related installation. It is the duty of the contractor to notify the architect or owner of any defects or design problems prior to installation of the Royal Edge Roofing System.

B1.03 QUALITY ASSURANCE AND WARRANTY

A twenty (20) year limited membrane only warranty is available for .060 membrane and a ten (10) year limited membrane only warranty is available for .045 membrane.

A labor warranty is available through our Registered Applicator Program and only if certain conditions are met.

Please Refer to the Warranty Section of this manual for further information regarding limited membrane only warranties and labor warranties.

All membrane and component parts of the total installation assembly must be supplied or approved by RPI.

The Limited Membrane Only Warranty shall be in effect upon the date of the completed installation, pending payment in full of all bills to RPI, and its suppliers.

NOTE: Ballast to be left off of all seams until after final inspection, if R.P.I. Labor Warranty has been requested.

B1.04 DESIGN CONSIDERATIONS

SUBSTRATE

It is the installer's responsibility to inspect the substrate for defects or incompatibility with RPI's Royal Edge Roofing Systems and to notify the architect, owner, or general contractor if problems are encountered.

Various decks may require an acceptable insulation and/or recovery/fiber board. Pull-out test of fasteners are recommended for mechanical attachment of insulation and/or recovery/fiber board.

The various decks may be:

1. Fluted steel, 24 gauge or heavier, through which at least 1/2 inch penetration through the deck with an appropriate screw fastener must be achieved. Due to the fluted design of steel decks, a specific effort is required to assure 1/2 inch penetration is attained in either the top or bottom of the flute, with the appropriate length fastener.
2. Structural concrete, rated at 3500 psi or greater, containing no light weight aggregate. Insulation may be attached by one of the following methods:
 - a. Mechanical attachment using a minimum one (1) inch penetration with a compatible concrete fastener.
 - b. Adhering using appropriate materials.
3. Gypsum, precast or poured in place concrete, through which a compatible type fastener, or an acceptable type adhesive system is employed.
4. A light weight insulating concrete, mesh reinforced, over composite form board decking, through which an RPI approved fastener is attached.
5. Cementitious fiber (Tectum), through which an RPI approved fastener is attached.

WOOD NAILERS

Wood nailers are recommended at all of the following:

1. All roof edges where insulation thickness is greater than 1/2 inch thick for reroofing, and all roof edges in new construction.
2. All expansion joints.
3. All pitch pockets greater than twelve (12) inches on any one (1) side.
4. Refer to RPI detail drawings for other nailer recommendations.

Wood nailers shall support the entire flange of all sheet metal.

VAPOR BARRIERS

Vapor barriers are recommended when high humidity of the building interior is a concern, and on freezer and cooler structures.

As an insulation precaution, vapor barriers should be used when the following conditions are anticipated:

1. Outside average temperature is below 40°F.
2. Expected interior relative humidity is 45% or greater.

INSULATION

Must meet ASTM's as specified for each type of insulation.

ROOFING CONSIDERATIONS

The owner or designate is responsible for the design and engineering of the roof deck and the compatibility of RPI's Royal Edge Roofing System with the roof deck.

All roof membrane and accessories shall be supplied or approved by RPI.

The roofing contractor shall not proceed with the installation until all defects in the substrate or the structural deck have been corrected.

Flashings and membranes must extend up a minimum of eight (8) inches on all protrusions and a minimum of twelve (12) inches on all parapet walls. If it is impossible to achieve the minimum application height, notify RPI.

Royal Edge EPDM Membrane cannot be adhered to uneven surfaces such as stucco, insulated wall panels, textured masonry, or corrugated metal.

RPI shall not be responsible for failure or damage to the Royal Edge Roofing System caused by errors in the underlying design, engineering, quantities or dimensions of the roofing system.

WALKWAY PADS

It is required that walkway pads or pavers to be installed at all points of access to the roof and around all units requiring regular maintenance

B1.05 ROOF DRAWINGS

In accordance with the warranty program, an overall roof drawing or diagram showing the dimensional size of the buildings roof system as well as the all the locations of the penetrations and protrusions in the roof must accompany the "Job Start Notification Form".

Flashing, perimeter, and termination details shall be noted on the overall roof diagram or itemized on a penetration detail sheet.

B1.06 ROOF DECK AND FLASHING SURFACES

Surfaces shall be free of sharp projections, and swept clean of all debris.

Surfaces, old or new, shall be free of contaminants, such as (but not limited to) asphalt, oil, grease, cement scale, paint, and similar materials.

If vertical surfaces will not accept bonding adhesive, the surface must be covered with a minimum 1/2 inch high density fiberboard, 1/2 inch CDX Plywood, 1/8 inch tempered hardboard, or 7/16 inch OSB properly fastened (a minimum of one (1) fastener per four (4) square feet) to the parapet and buildings vertical walls.

All applications shall be terminated a minimum of twelve (12) inches above the roof deck wherever possible.

B1.07 JOB CONDITIONS

No application of the Royal Edge Roofing System shall commence nor proceed during inclement weather. Temperatures below 40°F require special attention for the application of the Royal Edge EPDM Membrane. Follow the specified precautions for the storage of materials and expose only enough adhesives and sealants to be used within a reasonable period when using below 40°F.

NOTE: Adhesive drying time is extended in cold temperatures, and heat guns and heat boxes are necessary to assist in the proper application of flashings and seaming.

Do not install the Royal Edge Roofing System over ponding water, ice, snow, or saturated insulation that will cause future condensation, dry rot, or insulation deficiencies.

WARNING: DO NOT BREATHE THE VAPORS OF THE ADHESIVES OR SEALANTS OR USE THEM NEAR A FIRE OR OPEN FLAME, FOR THEY CONTAIN PETROLEUM DISTILLATES THAT MAKE THEM EXTREMELY FLAMMABLE.

During installation do not expose the Royal Edge Membrane or accessories to a constant temperature in excess of 180°F. **NOTE:** DO NOT ALLOW ADHESIVES, FLASHINGS AND CAULKING TO FREEZE.

Materials used in the splicing procedures are **EXTREMELY FLAMMABLE**. Do not use near an open flame or in an unventilated or confined area. Dispense only from a UL listed or approved safety container.

Do not use oil based or plastic roof cement to adhere the Royal Edge Cured Membrane. Plastic roof cement can only be used with Uncured Royal Edge Flashing Membrane on tie-ins.

Do not allow waste products such as petroleum, oil, grease, solvents, vegetable or mineral oil, animal fat or direct steam venting to come into contact with the Royal Edge Membrane.

B1.08 STORAGE OF MATERIALS

All materials shall be stored in their original tightly sealed containers or unopened packages and shall be clearly labeled with the manufacturer's name, brand name, and batch number of the material, where appropriate. All materials, except the Royal Edge Membrane, shall be stored out of the weather in a clean dry area.

Liquid materials such as adhesives, thinners, and cleaners shall be stored in areas away from sparks, open flames, and excessive heat.

WARNING: **ADHESIVES ARE FLAMMABLE.**
ADHESIVES OPENED IN CONFINED SPACES ARE TOXIC.
USE ONLY IN WELL VENTILATED AREAS.

Store materials, except for the Royal Edge Membrane, between 60° and 80°F. If exposed to lower temperatures, restore to proper temperature before using. Damaged materials will be replaced at contractor's expense.

B1.09 SURFACE PREPARATION

The owner, architect, or designate shall be responsible for providing a structurally sound and proper roof deck to receive the Royal Edge Roofing System. The roofing contractor shall notify the owner or designate, in writing, of defects in the substrate and work shall not proceed until defects have been corrected.

Surfaces on which the Royal Edge Membrane is to be applied shall be clean, smooth, and free of fines, sharp edges, loose, and foreign material such as oil and grease.

Before laying insulation board, the roof surface shall be broomed to remove loose gravel to help eliminate potential overweight structural problems.

Prior to installation, all unused pipes, skylights, curbs, and other protrusions should be removed.

B2.00 MATERIALS

B2.01 MEMBRANE AND FLASHING MATERIAL SPECIFICATIONS

Membrane for this work shall conform to the specifications contained in the General Section page G-7 of this manual and shall be a nominal .060 Mil thick vulcanized Royal Edge EPDM (ethylene propylene diene monomer) compounded elastomer.

Flashing materials shall be Royal Edge nominal .060 mil thick, uncured moldable EPDM Flashing Membrane.

WARNING: SHEET MEMBRANE IS EXTREMELY SLIPPERY WHEN WET.

B2.02 COMPONENT MATERIALS

All component materials necessary for the proper installation of the Loose Laid and Ballast system are to be furnished by Roofing Products International, Inc. Use of component materials furnished by other vendors will void any express or implied warranties in connection with the performance of the system.

1. Bonding Adhesive (Solvent Based)
2. Splicing Adhesive (Rubber-to-Rubber)
3. Seam Tape
4. Seam Tape Primer
5. Lap Caulk (Paste Sealant)
6. Membrane Cleaner
7. Pourable Sealer
8. Water Cut Off Mastic or WaterBloc Tape
9. Termination Bar and Fasteners
10. Fasteners
11. Uncured Flashing Membrane
12. Prefabricated Pipe Boots
13. Walkway Pads
14. Prefabricated Drain Sleeves
15. One-Way Moisture Vents
16. Stone Mat Separator Sheet
17. Batten Bar

B2.03 COMPONENT MATERIALS

B3.01 INSULATION INSTALLATION

Any UL or FM approved insulation that is compatible with the adhesives is acceptable. Comply with the manufacturer's instructions for installation.

Insulation board shall be laid on the roof surface and butted together. Stagger joints with no gaps greater than 1/8 inch. If more than one (1) layer is used, offset joints of the first layer to the joints of the second layer.

Unless otherwise required, insulation should be installed according to these instructions. If not, install according to insulation manufacturer's published recommendations.

Do not lay more insulation board than can be covered with the Royal Edge Membrane by the end of the working day.

Please refer to the UL and FM Classification Directories for additional information on insulation.

B3.02 MEMBRANE INSTALLATION

Lay the Royal Edge Membrane over the insulation, removing all wrinkles and arrange the sheet exactly to the desired position. NOTE: Avoid stretching the membrane.

Allow the membrane to relax to effect a minimum six (6) inches to the adjacent sheets.

Allow enough membrane at roof edge to cover parapet walls, gravel stops, or extensions into the gutter.

The Royal Edge EPDM Membrane shall be fully adhered to the mechanically attached substrate using RPI Bonding Adhesive six (6) feet around the perimeter, and nine (9) inches around all protrusions and penetrations.

NOTE: No six (6) foot perimeter adhesion is required when doing a base anchor wall detail.

Mix the bonding adhesive by stirring thoroughly to the bottom of the container. DO NOT THIN THE ADHESIVE.

Using a solvent accepting paint roller or a spraying device, apply an even coat of adhesive, avoiding globs and puddles, to both the Royal Edge Membrane and the insulation/substrate. Solvent Based Bonding Adhesive should be applied at an even coverage of approximately 350 square feet per five (5) gallon can. DO NOT APPLY TO THE SPLICE AREAS.

Allow bonding adhesive to dry to the touch (Not stringy to the finger touch). Roll coated sheet of Royal Edge Membrane into coated insulation/substrate at the six (6) foot perimeter, making sure to keep the middle of the sheet ahead of the ends so as to avoid wrinkles. If difficulty is incurred fully adhering the nominal .045 Royal Edge Membrane then change to the nominal .060 Royal Edge Membrane.

Using a stiff push broom, broom the bonded portion of the sheet to the substrate to insure 100% adhesion.

Ballast weight per square foot shall be determined by architect, structural engineer, specifier, but should not be less than twelve (12) pounds per square foot on the overall poundage per square foot for the total roof area.

Install one layer of RPI Stone Mat Separator Sheet (.045 ONLY) on top of the Royal Edge EPDM over lapping each sheet six (6) inches, prior to the installation of the ballast.

Ballast will be river washed round stone, minimum 3/4 to 2 1/2 inches in diameter (90% retention on a 3/4 inch screen). Smooth paving blocks, concrete pavers, or processed stone can be used alternate to the river washed round stone with the RPI Stone Mat Separator Sheet placed on top of the Royal Edge Membrane.

Fold back the membrane so that one-half (1/2) of the underside is exposed. Be sure that the sheet fold is smooth and free of wrinkles.

Repeat the process with the remaining sheets.

A3.03 SPLICING

A. ADHESIVE

1. Fold the sheet back to effect a minimum six (6) inch splice.
2. Clean both mating surfaces with a sponge mop saturated with RPI Membrane Cleaner. It is extremely important to frequently dip the sponge mop to remove all talc, dirt, and other contaminants.

3. Apply RPI Splicing Adhesive to both mating surfaces, extending a minimum of one (1) inch beyond the splice area, using a solvent resistant paint brush or roller. Adhesive should be applied at a minimum rate of approximately 120 to 140 lineal feet of six (6) inch splice per one (1) gallon. Brush or roll on the splicing adhesive to obtain 100% coverage. Do not allow the adhesive to glob or puddle. Allow adhesive to dry until tacky (i.e. not sticking to a dry finger touch).
4. Roll the top membrane onto the bottom membrane and allow it to fall freely into place without stretching or wrinkling (fishmouths). Immediately apply pressure to bring the bonded surfaces into 100% contact.
5. Using a steel hand roller, roll the entire length of spliced area toward the outer edge at a 45° angle.
6. Clean the spliced edge with RPI Membrane Cleaner, extending a minimum of one (1) inch onto the top and bottom sheets to remove all talc, dirt, or other contaminants.
7. Apply a minimum 1/4 inch bead of RPI Lap Caulk along the edge of the splice forming a bridge between the two mated sheets of the Royal Edge Membrane. Do not feather or tool the bead of lap caulk.

NOTE: It is advisable to allow the seam to set for twenty four (24) hours prior to applying the lap caulk in order to allow all the adhesive solvents to dissipate. If adverse weather conditions are expected apply the lap caulk at the end of the day.

B. SEAM TAPE

1. Fold sheet back as to effect a minimum four (4) inch splice.
2. Clean both mating surfaces with a sponge mop saturated with RPI Membrane Cleaner. It is extremely important to frequently dip the sponge mop to remove all talc, dirt, and other contaminants.
3. Prime the splice area using RPI Seam Tape Primer applied at the minimum rate of 200 to 250 lineal feet per one (1) gallon.
4. Snap a chalk line 1/4 inch from the underside of seam of membrane, allow 1/8 inch extra tape to remain beyond the lap edge to act as a water barrier. NOTE: Presnap chalk line in the air to remove any excess chalk dust. Seam tape will not adhere to chalk dust.
5. Line up seam tape and unroll with release paper in place. Run the tape 1/8 inch back from the chalk line. Do not back up or a ridge will form in the seam tape. The tape has a very aggressive tack; do not touch the tape, and never permit the tape surface to touch itself. Roll the surface with the release paper in place to assure complete contact with the overlapping membrane. Anything less than 100% adhesion is not acceptable.
6. Flop over the top membrane and remove the release paper at a 90° angle along the seam slowly to mate top and bottom of splice without air pockets forming.
7. When finishing one roll, overlap the start of the next roll up onto the end of the previous roll a minimum of 1 inch. Knead the ridge that will be formed with a steel hand roller.
8. Using a Steel hand roller, roll the entire length of spliced area toward the outer edge at a 45° angle, and then length wise to assure 100% adhesion. A 2 step process.
9. Clean the spliced edge with RPI Membrane Cleaner, extending a minimum of one (1) inch onto the top and bottom sheets to remove all talc, dirt, or other contaminants.
10. Apply a minimum 1/4 inch bead of RPI Lap Caulk along the edge of the splice forming a bridge between the two mated sheets of the Royal Edge Membrane at all seam tape roll overlaps. Do not feather or tool the bead of lap caulk.

C. T-JOINTS

1. SPLICING ADHESIVE

All T-joint splice intersections are to be patched over using a minimum six (6) inch diameter uncured Royal Edge Membrane with rounded corners centered over T-joint. Using a steel hand roller, roll the entire patch attaining 100% adhesion. Apply a minimum 1/4 inch bead of RPI Lap Caulk along the exposed edge forming a bridge between the two sheets of membrane. Do not feather or tool the bead of lap caulk.

2. SEAM TAPE

All T-joint splice intersections are to be patched over using a minimum six (6) inch diameter uncured Royal Edge Membrane with rounded corners centered over T-joint. Using a steel hand roller, roll the entire patch attaining 100% adhesion. Apply a minimum 1/4 inch bead of RPI Lap Caulk along the exposed edge forming a bridge between the two sheets of membrane. Do not feather or tool the bead of lap caulk.

B3.04 NAILERS

Nailers are required to be installed at the perimeter of each roof level, curb flashing, skylights, expansion joints, and similar penetrations. Wood nailers shall be installed at all gravel stop or drip edge perimeters of each roof level. Pressure Treated wood nailers are required. Creosote and asphalt preservatives are not acceptable.

Attach wood nailers to resist a wind force of one hundred twenty five (125) pounds per lineal foot or as recommended by FM Loss Prevention Data Bulletin I-49. The thickness of the nailer shall be such that the top is flush with the surface to which the Royal Edge Membrane is to be applied.

B3.05 FLASHING

Flashing should be installed in accordance with RPI detail drawings.

Cured Royal Edge Membrane is to be used for flashing parapet walls, and curbs. Refer to RPI's standard flashing detail drawings.

Uncured Royal Edge Membrane is to be used on all outside corners, vents, chimneys, skylights, and pipes. Two (2) layers of uncured Royal Edge Membrane is to be used on all flashings of outside corners, pipes, and one layer on radical bends of the field seams. Install the Royal Edge Uncured Membrane with RPI Splice Adhesive. Refer to RPI's standard flashing details.

PARAPET WALLS AND CURBS (Cured Royal Edge Membrane)

1. Surface should be clean and free of contaminants, loose old flashings, have to be removed.
 - a. Cut Royal Edge Membrane at base of wall, or extend it up parapet a minimum of two (2) inches above roof deck.
 - b. Mechanically attach membrane using RPI's Batten Bar. Mechanically attach batten bar every twelve (12) inches.
 - c. Cut a piece of cured Royal Edge Membrane which will extend up the parapet wall or curb a minimum of twelve (12) inches, and will extend out onto the deck a minimum of six (6) inches.
 - d. Apply RPI Bonding Adhesive to parapet wall or curb and the Royal Edge Membrane. Apply RPI Splicing Adhesive to Batten Bar and Royal Edge Membrane making sure to extend out onto the roof deck a minimum of six (6) inches.
2. When a field seam changes plane, a six (6) inch wide by twelve (12) inch long piece of uncured Royal Edge Membrane must be installed over the center of the seam using RPI Splicing Adhesive. Make sure the cover strip extends up the parapet wall and out onto the deck a minimum of six (6) inches.

EXPANSION JOINTS

1. See RPI standard detail for expansion joints.

DRAINS

1. Drains with clamping rings: Refer to RPI standard drain detail drawing.
2. Drains using RPI one piece sleeve: Refer to RPI standard sleeve detail drawing.

For various flashing termination's, refer to RPI's detail drawing.

B3.06 NIGHT SEAL

Care should be taken to insure that water does not flow beneath any completed sections of the roof. Loose edges of the Royal Edge Membrane should be temporarily sealed with RPI's Royal Edge Uncured Membrane, Water Cut Off Mastic, Pourable Sealer when the weather is threatening, or finishing up for the day.

Gravel should be scraped down to the felts on the existing built up roof in the area where the temporary night tie-in is to be made for proper night sealing.

Apply water cut off mastic at a minimum rate of twenty (20) lineal feet per tube on a smooth surface, twelve (12) inches back from the edge of the sheet onto the exposed existing surface. A trowel should be used to spread the material in order to achieve complete sealing. This coverage will be reduced on existing built up roof surfaces according to surface preparation.

After embedding the Royal Edge Membrane in the RPI Water Cut Off Mastic or Pourable Sealer, check for continuous contact. Weight the edge, providing continuous pressure over the length of the tie-in

RPI does not assume responsibility for any night seal.

B3.07 WALKWAY PADS

RPI Roof Walkway Pads or Pavers are required in areas whenever foot traffic is anticipated. See RPI standard detail drawing.

B3.08 PROTECTION

- a. The contractor shall protect this system from all trades not directly under his supervision.
- b. Any damage to this system shall be repaired before warranty acceptance of the system, and the cost of the repairs will be borne by those responsible for such damages.

B3.09 CLEAN UP

The applicator shall remove all materials and debris from the work and storage areas, and leave those areas in an undamaged and acceptable condition.

As a supplier of materials only, Roofing Products International, Inc., 57460 Dewitt Street, Elkhart, IN 46517 does not assume responsibility for errors in design, engineering, quantities or dimensions. All materials are to be applied in strict accordance with manufacturer's printed instructions. Specifier to verify all dimensions, sizes and structural soundness.

**NEW BALLASTED
ROOFING SYSTEM**

**NEW ADHERED
ROOFING SYSTEM**

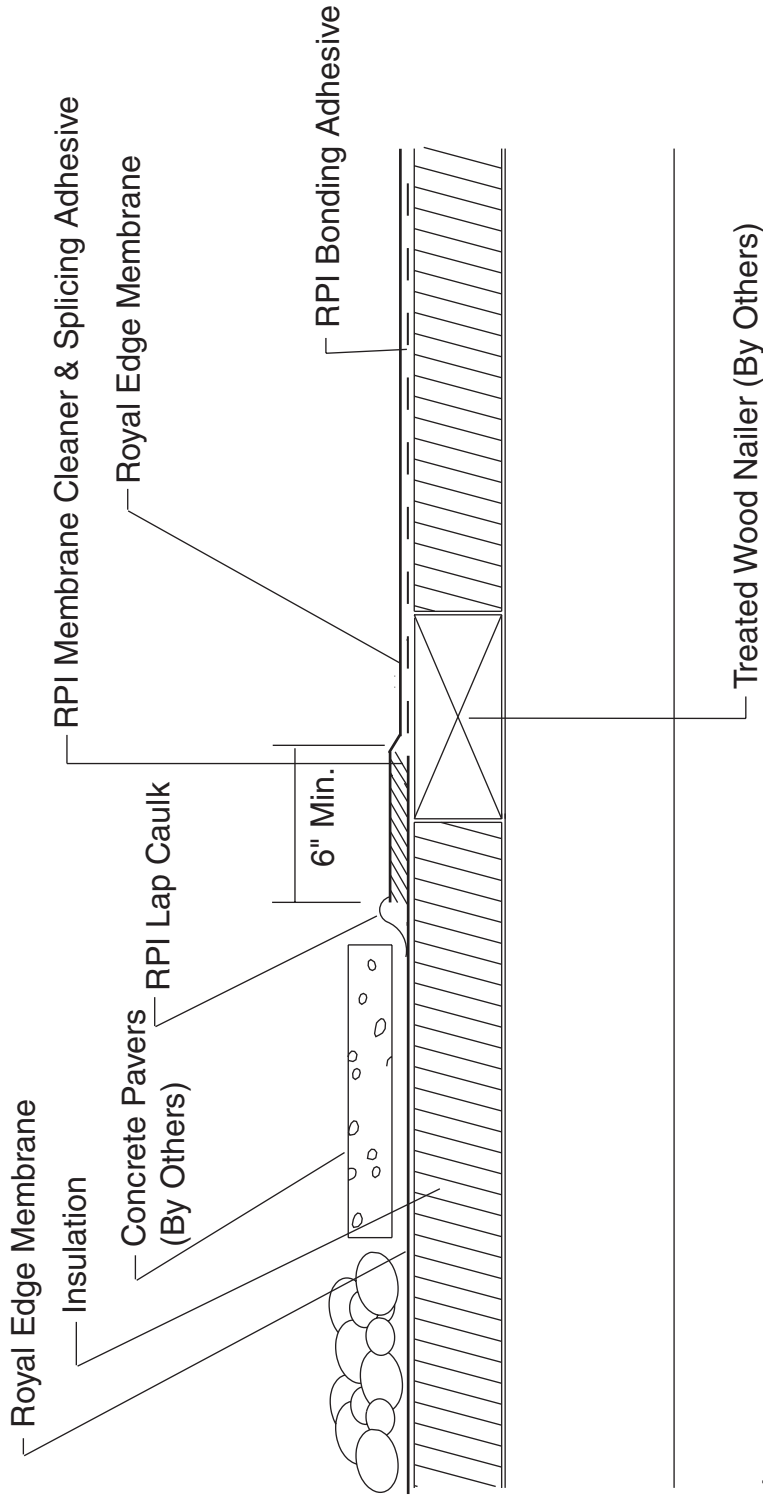

Note:

RPI Stone Mat Is Required When Using .045 Royal Edge Membrane

**B-1
BALLASTED TO FULLY ADHERED TIE-IN**



NEW BALLASTED ROOFING SYSTEM

NEW MECHANICALLY-ATTACHED ROOFING SYSTEM

2" Diameter Seam Plates Are Required
For Mechanically-Attached Reinforced
Roofing Systems Or Batten Bar With
Non Reinforced Systems

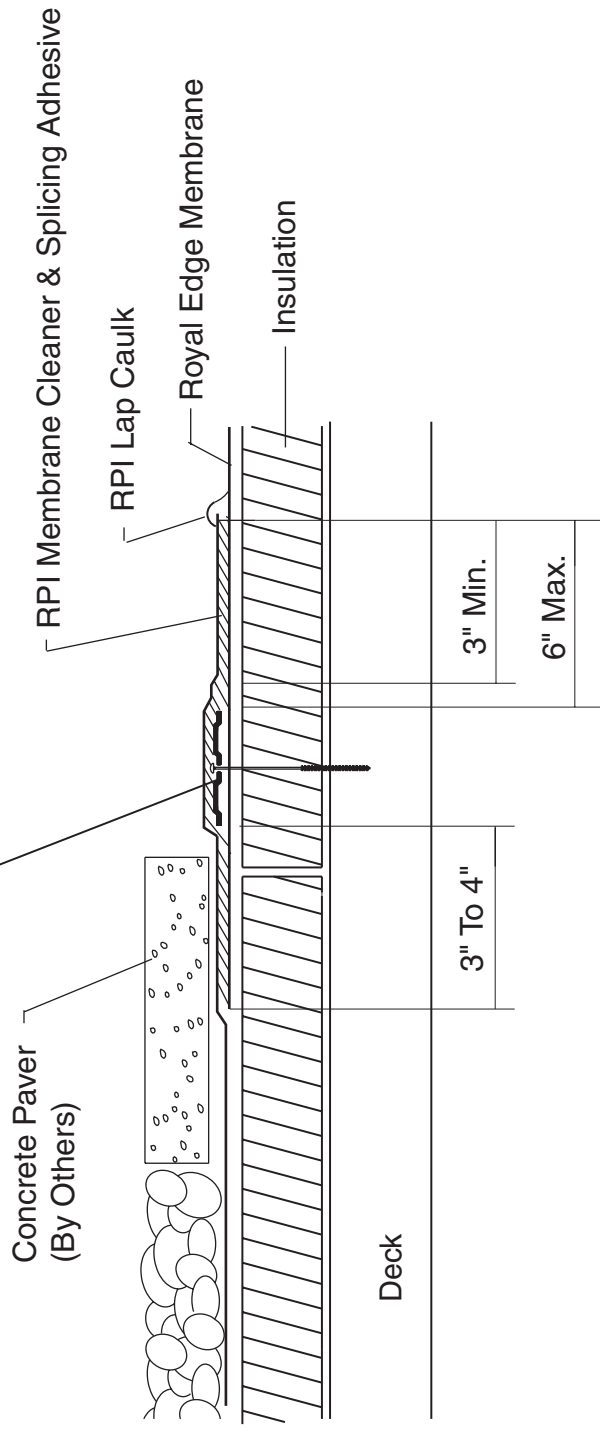

B-2 BALLASTED TO MECHANICALLY-ATTACHED TIE-IN



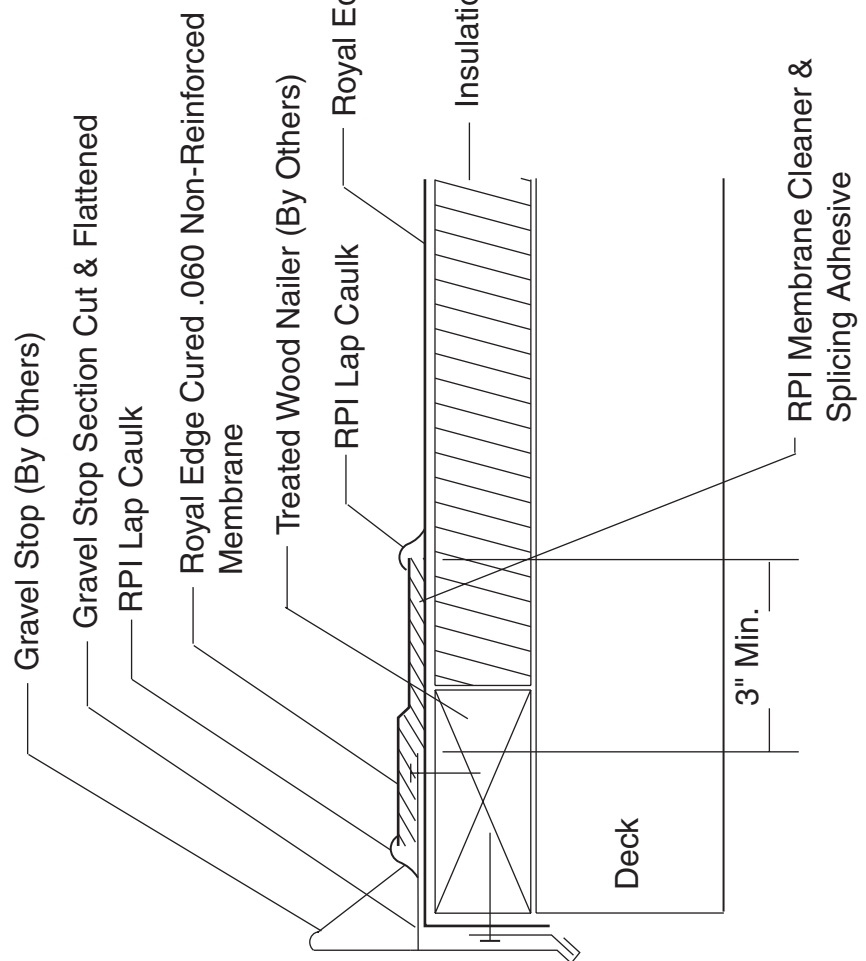
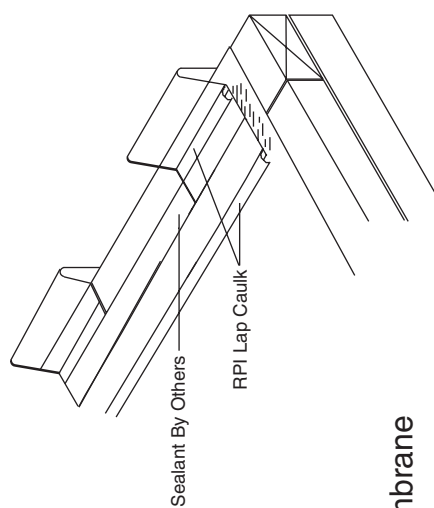

Notes:

1. For Gravel Stop Installation, See Gravel Stop Detail for Corresponding Design.
2. For Proper Drainage on Roofing Systems, Consult Specifier or Local Codes for Acceptable Ballast Retainer.
3. RPI Stone Mat is Required When Using .045 Membrane.

B-3 GRAVEL STOP SCUPPER USING CURED COVER STRIP



A New Construction Or Tear-Off

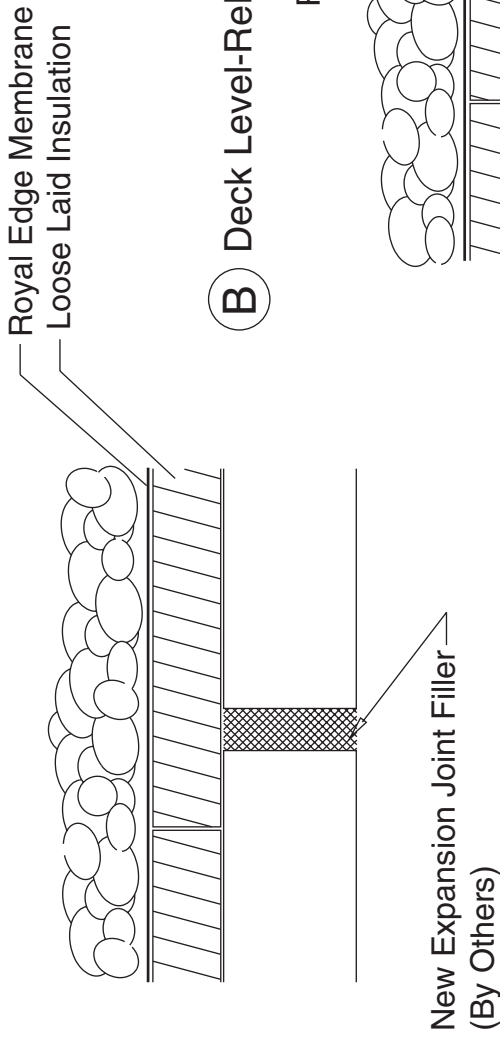

B Deck Level-ReRoofing

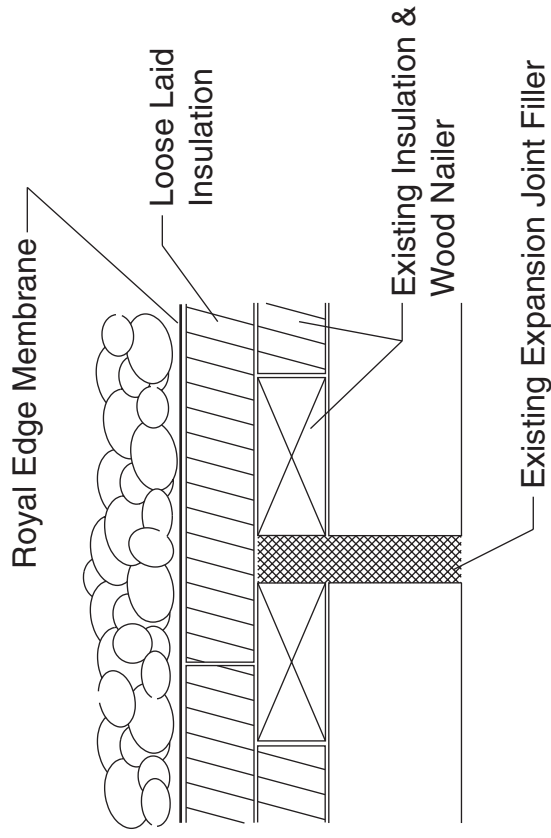

Note:

RPI Stone Mat Separator Sheet Must Be Used When Using .045" Royal Edge Membrane.

B-4
FLAT EXPANSION JOINT



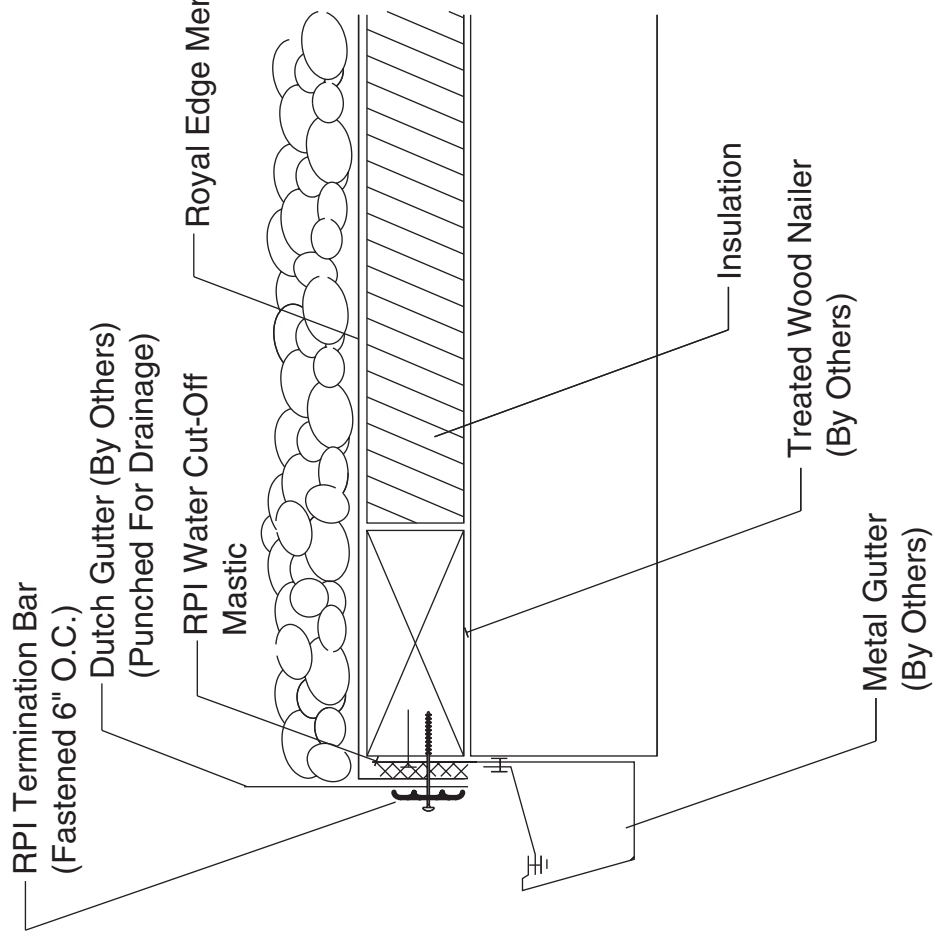
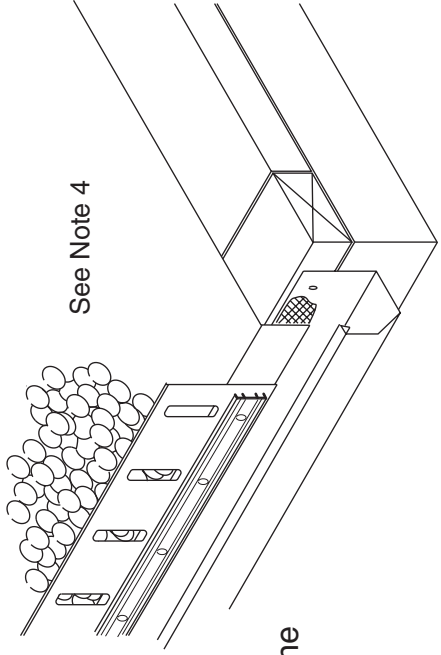

Notes:

1. Fastener Pattern Of Termination Bar Must Provide Constant Compression On RPI Water Cut-Off Mastic.
2. Dutch Gutter Must Extend Above Gravel Surface Sufficiently To Retain Gravel & Prevent Gravel Migration.
3. Refer To Local Codes For Proper Drainage Requirements.
4. Slots In Dutch Gutter Must Be Flush Or Below Membrane Level.
5. RPI Stone Mat Separator Sheet Must Be Used When Using .045" Royal Edge Membrane.

**B-5
DUTCH GUTTER**



NOT FOR USE WITH INVERTED ROOF SYSTEMS

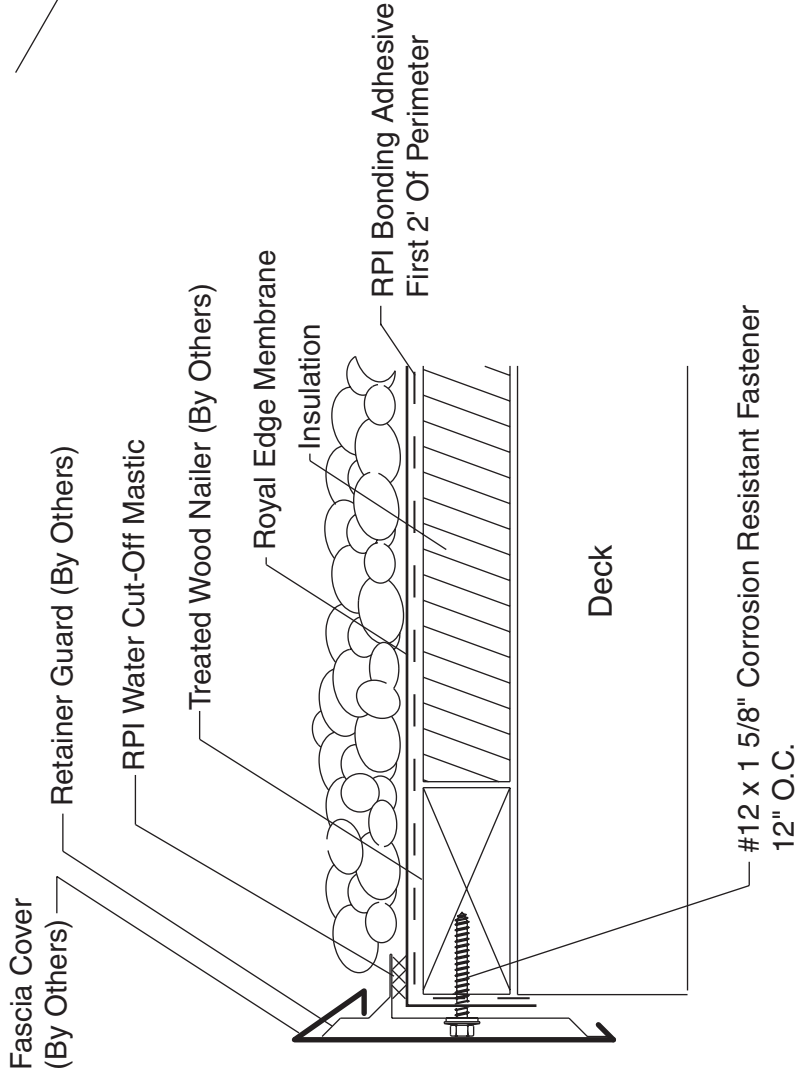
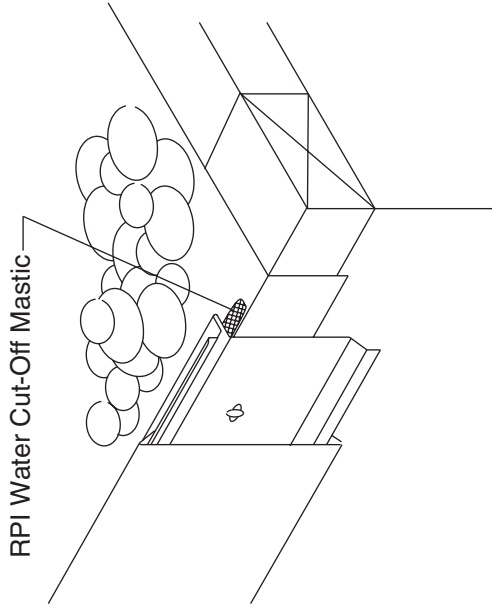

Notes:

1. If Incidental/Temporary Ponded Water Is Expected, The Metal Edge Must Be Elevated & Scuppers Provided For Drainage.
2. Refer To Metal Edge Mfg. For Specific Installation Details and/or requirements.

**B - 6
GRAVEL STOP (FOR BALLASTED SYSTEMS)**



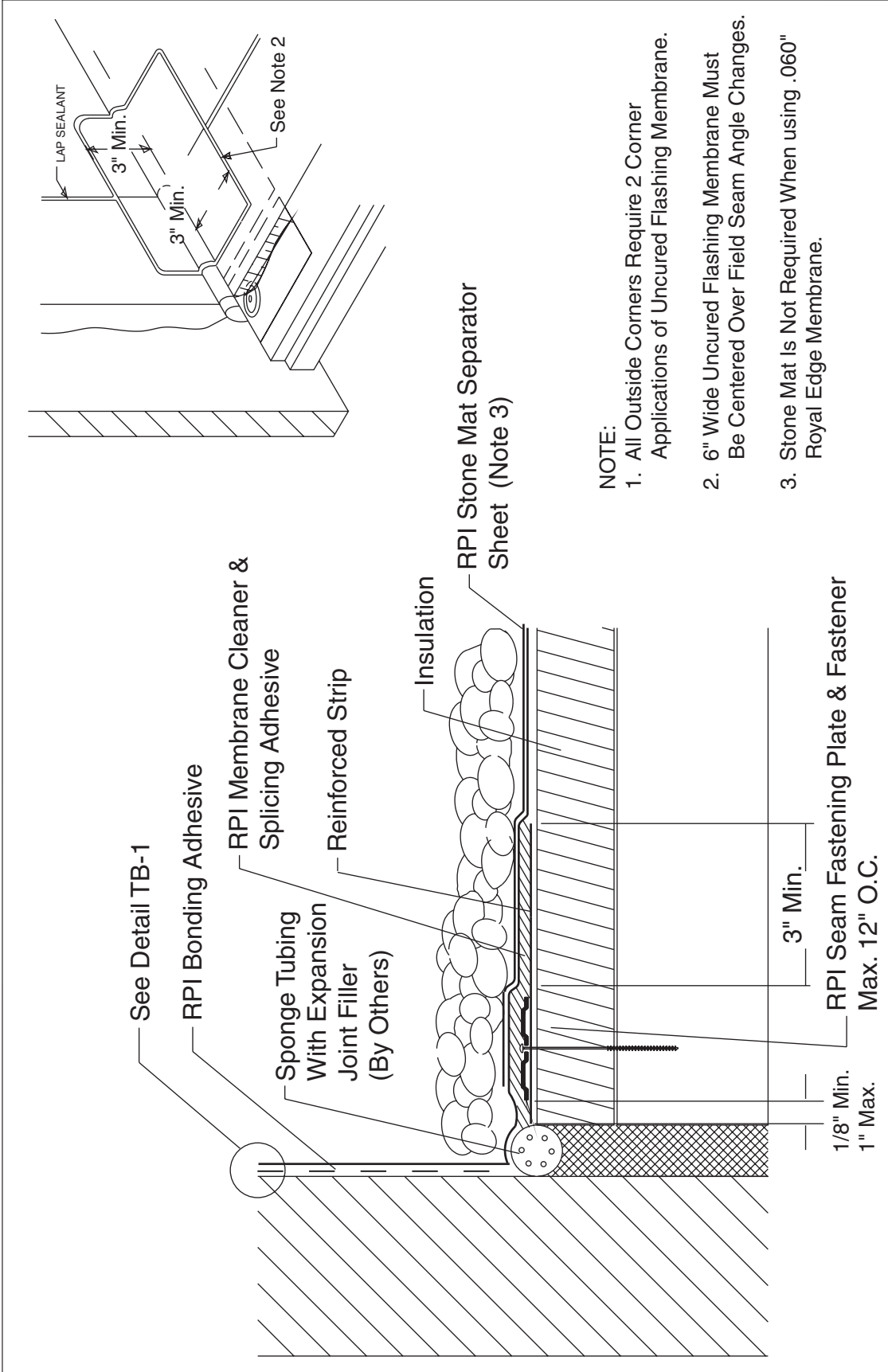

NOTE:

1. All Outside Corners Require 2 Corner Applications of Uncured Flashing Membrane.
2. 6" Wide Uncured Flashing Membrane Must Be Centered Over Field Seam Angle Changes.
3. Stone Mat Is Not Required When using .060" Royal Edge Membrane.

B-7 ROOF-TO-WALL EXPANSION JOINT USING REINFORCED STRIP



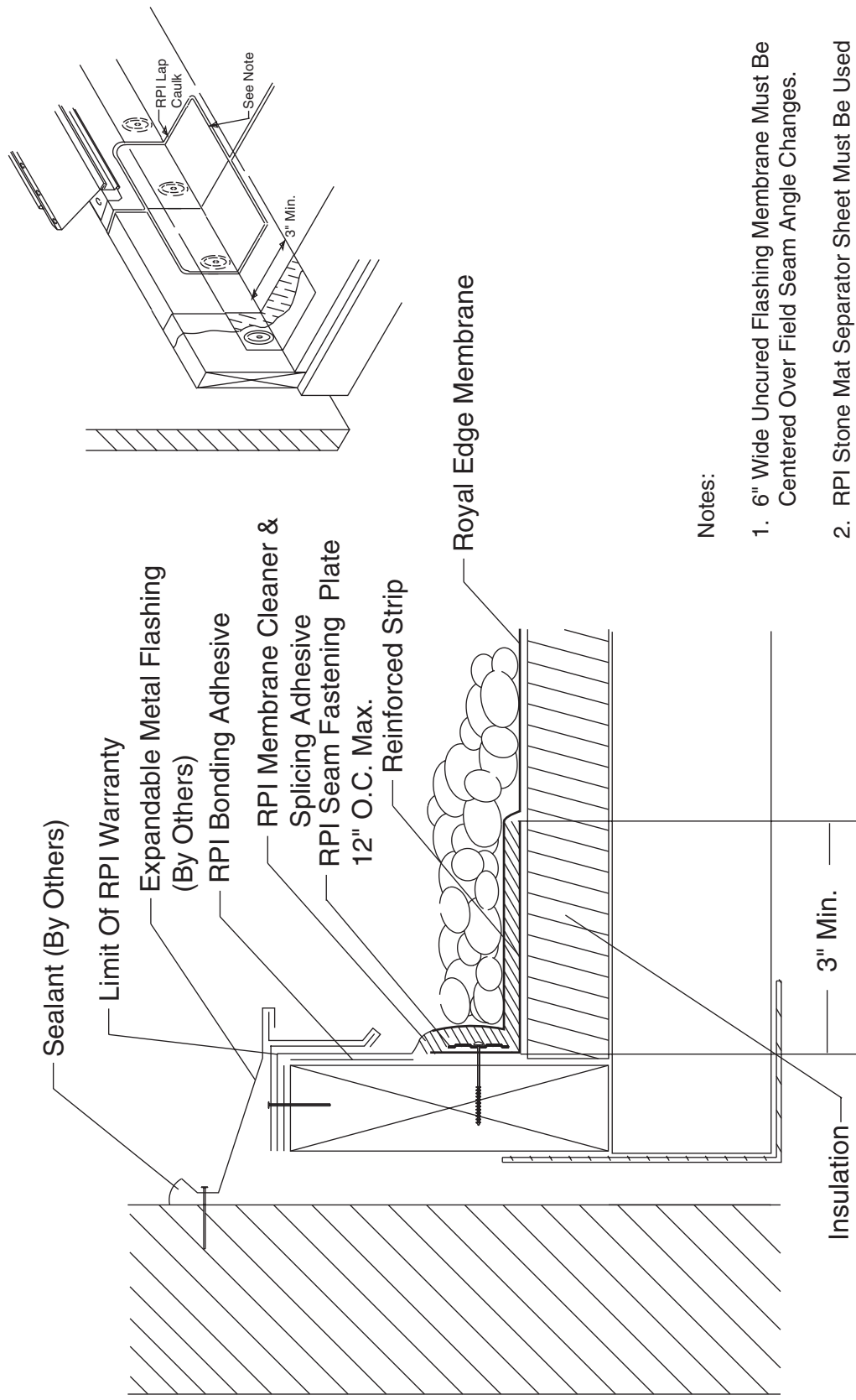

Notes:

1. 6" Wide Uncured Flashing Membrane Must Be Centered Over Field Seam Angle Changes.
2. RPI Stone Mat Separator Sheet Must Be Used When Using .045" Membrane.

B-8
SHEAR EXPANSION JOINT USING REINFORCED
STRIP



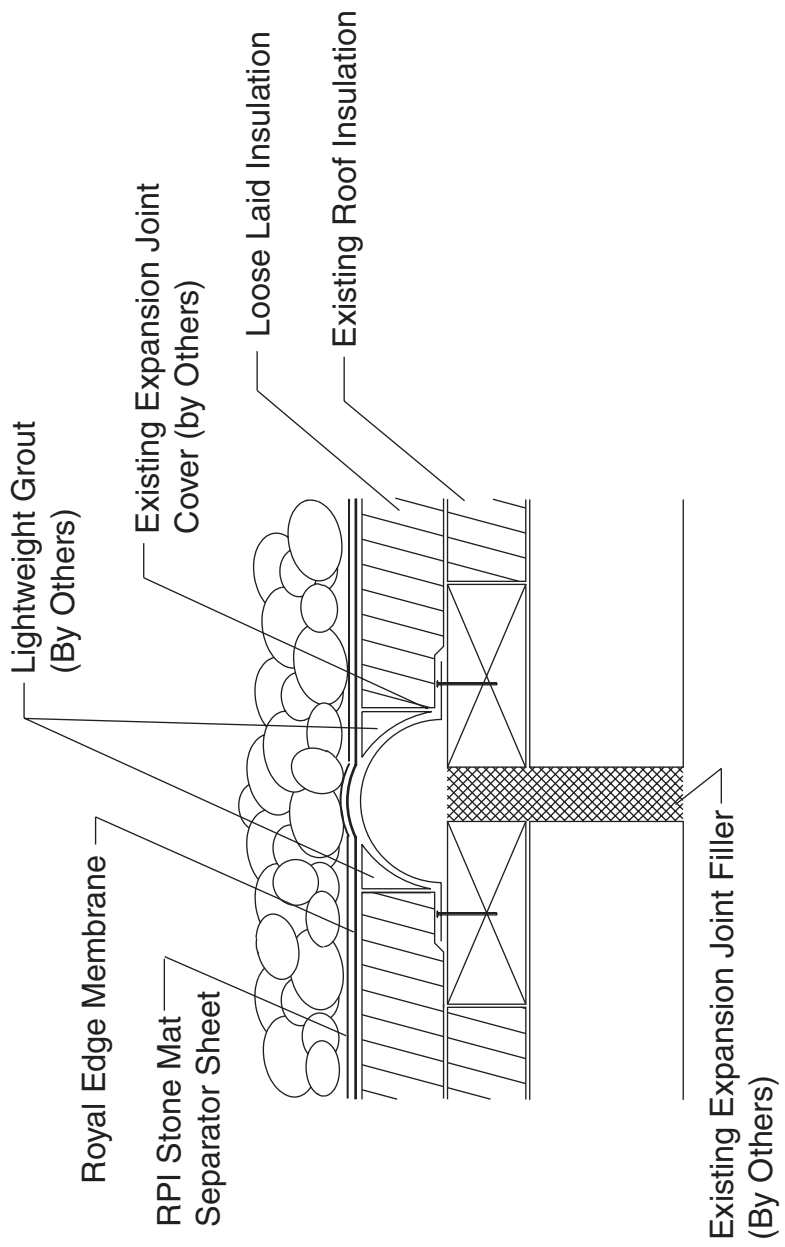

Notes:

1. Protective Layer Of Insulation Or Stone Mat Must Be Provided Between Existing Metal Joint Cover & Royal Edge Membrane.
2. Stone Mat Is Not Required When using .060" Royal Edge Membrane.

**B- 9
EXISTING EXPANSION JOINT COVER**



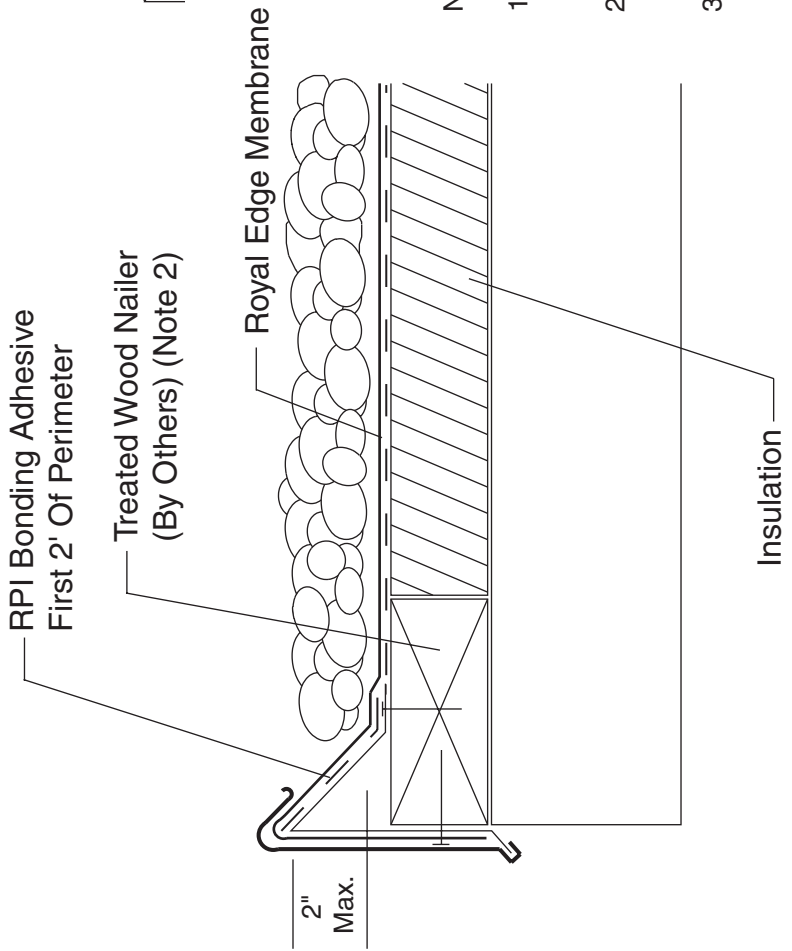
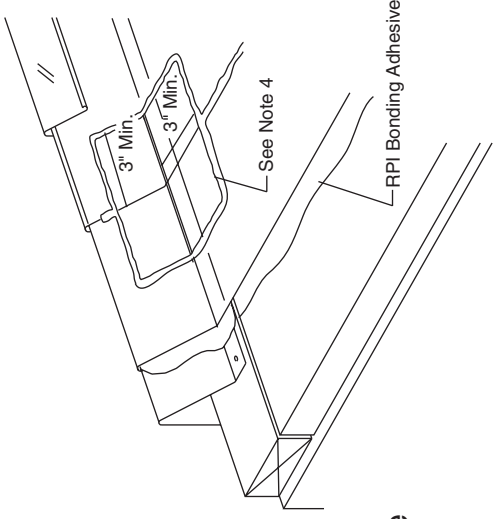

Notes:

1. Fasteners & Fastener Pattern As Recommended By Gravel Stop Mfg.
2. Treated Wood Nailers Must Extend Past Total Width Of Gravel Stop Deck Flange.
3. Gravel Stop Must Extend Above Gravel Surface Sufficiently To Retain Gravel & Prevent Gravel Migration.
4. 6" Wide Rpi Uncured Flashing Membrane Must Be Centered Over Field Seam Angle Changes.
5. RPI Stone Mat Separator Sheet Must Be Used When Using .045" Membrane.

**B- 10
SNAP-ON GRAVEL STOP**



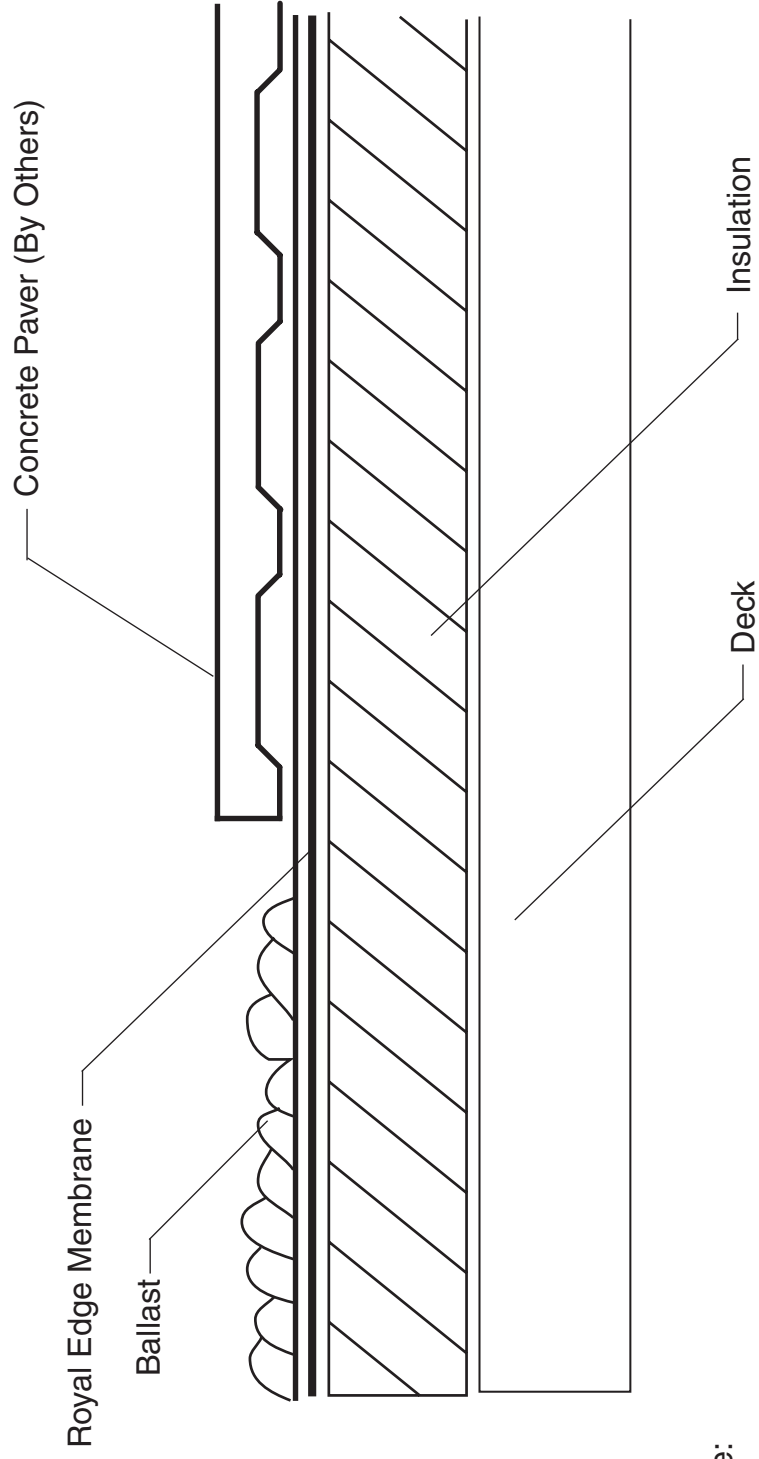

Note:

RPI Stone Mat Separator Sheet
 Not Required When Using .060
 Royal Edge Membrane

**B-11
 STONE MAT**



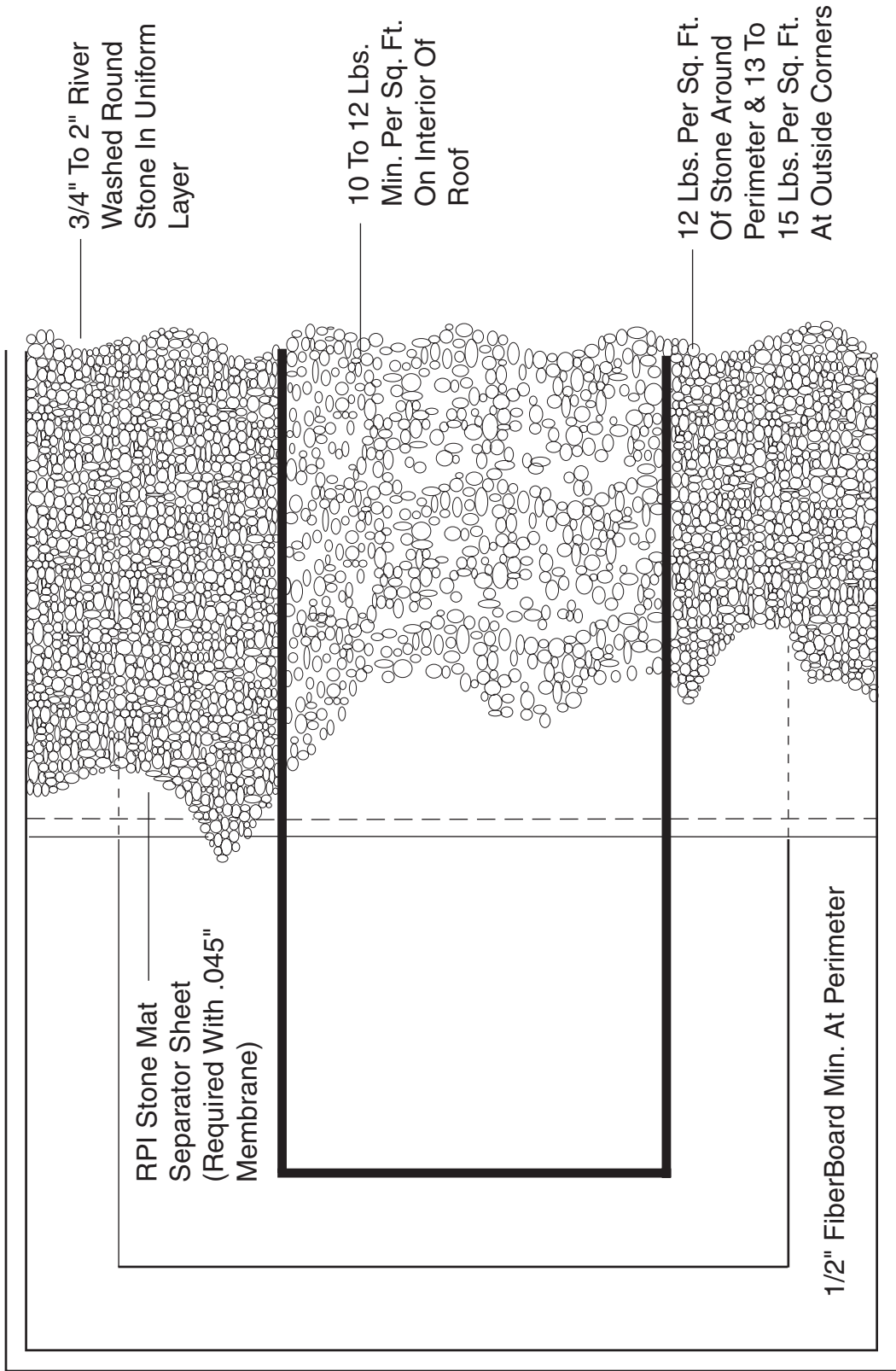

BALLAST LAYOUT